

# 10K Foot Valve

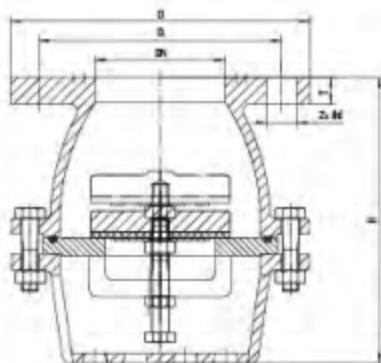

## Specifications

Basic standard
● Flange end: KS B 1511/JIS
Feature
● PN: 10K
● Shell test(water): 2.1mpa
● Suitable temperature: ≤80(℃)
● Suitable medium: water

## Main parts and materials

Part Name	Material
Body	Cast Iron
Disc	Cast Iron
Disc Ring	NBR
O-ring	NBR

## Dimensions

DN	D	D1	Z×Φd	H	T
50	Φ155	Φ120	4×Φ19	162	14
65	Φ175	Φ140	4×Φ19	167	14
80	Φ185	Φ150	8×Φ19	177	16
100	Φ210	Φ175	8×Φ19	206	18
125	Φ250	Φ210	8×Φ23	256	20
150	Φ280	Φ240	8×Φ23	302	20